

## 2-LEVEL HYDRAULIC STACKER TECHNICAL SHEET

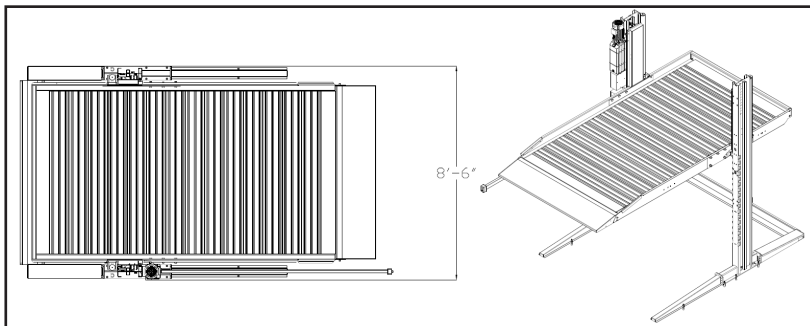

### FEATURES

- Double cylinder
- Easy disassembly and relocation
- Integrated control box for easy wiring
- 17 full range anti-fall locks
- Emergency stop button
- Safety key switch controller
- Limit switch
- Hydraulic overload protection
- Anti-skid ramp and platform
- Anti-rust power coating finishing
- Adjustable ground level vehicle height

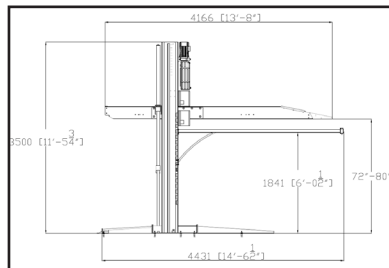

<b>MODEL</b>	2LHS-6000
<b>EQUIPMENT HEIGHT (MIN)</b>	11' - 8"
<b>EQUIPMENT WIDTH</b>	8' - 6"
<b>EQUIPMENT LENGTH</b>	14' - 6 <sup>1</sup> / <sub>2</sub> "
<b>EQUIPMENT WEIGHT</b>	2,423 lbs
<b>VEHICLE HEIGHT (TOP LEVEL)</b>	Dependent on total clear height
<b>VEHICLE HEIGHT (GROUND LEVEL)</b>	6' to 6' - 8" (adjustable)
<b>VEHICLE WIDTH (MAX)</b>	6' - 10 <sup>1</sup> / <sub>2</sub> "
<b>VEHICLE LENGTH (MAX)</b>	17' - 1"
<b>VEHICLE WEIGHT (MAX)</b>	6,000 lbs
<b>CONTROL BOX</b>	Integrated Module
<b>POWER PACK</b>	2.2 kw hydraulic power
<b>ELECTRICAL CONFIGURATION</b>	208-480V, 1 or 3 phase 60 Hz
<b>CONTROL POWER</b>	24V
<b>RETRIEVAL TIME</b>	30 seconds